

Side Mounting DTS Series

2000 BTU/H



Description

- Compact design for side mounting on any enclosure surface where hot spot cooling or low capacity cooling is required.
- Closed loop cooling ensures clean enclosure air is recirculated without ever mixing with contaminated ambient air.

Standards

- Maintains NEMA 12 rating
- IP 54
- UR, cUR and CE

Features

- R134a refrigerant.
- Thermostat control.
- Line cord with plug (115 V).
- Washable filter mat protected within an easily removable grill.

- Expansion valve permits increased efficiency through improved evaporator heat transfer and less frequent compressor operation.
- Built in condensate evaporator.
- Continuous air circulation from high capacity fans.
- EMI/RFI suppression meets CE.
- Gasket, mounting kit and template for cutout and drilling are included.
- Condensate drain hose and clamp.
- Exterior case easily removable for field service.
- Q Mount allows unit to hang in place for easy installation.

Accessories

- Gaskets...see page 456

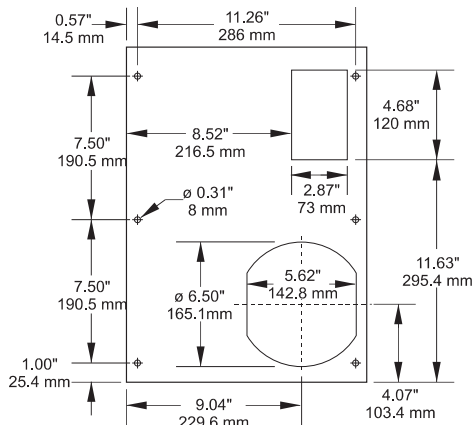

Drilling Template

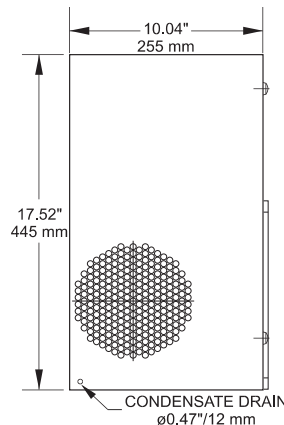

Left Side View

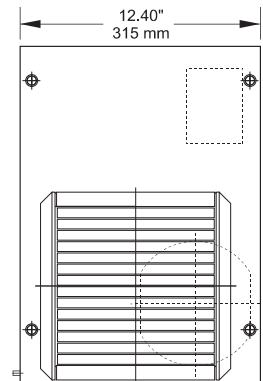

Front View

Part Number	Ship Wt. lbs
DTS2000A115LG	54
DTS2000A230LG	54

Technical Data

Electrical Data	DTS2000A115LG	DTS2000A230LG
Rated Voltage	115 V 60 Hz 110 V 50 Hz	230 V 50/60 Hz
Range of Operation	103-127 V	207-253 V
Power Consumption	270 W	230 W
Running Amps	2.9 A	1.3 A
Starting Current	13.8 A	7.4 A
Line Cord	With plug	Without plug

Refrigeration Data

Rated Capacity	2,000 BTU/H (580 Watts)
Type of Refrigerant	R134a
Adjustable Control Range	+77...+131 F / +25...+45 C Factory Setting +95 F (+35 C)
Max. Ambient Air Temp.	+125°F (+52°C)
Min. Ambient Air Temp.	+46°F (+8°C)
Air Capacity (unrestricted)	Internal Circulation 230 CFM External Circulation 230 CFM
Condensate Discharge	Condensate evaporator
Filter Mat	150 g/m ²
Db Noise Level	≤ 62 dB(A)
Unit Weight	51 lbs (23 kg)
Exterior Case	Galvanized sheet steel
Finish	RAL7035 light grey finish
NEMA Rating	Enclosures IP 54/NEMA 12

All dimensions in inches unless specified otherwise